

MAGNETIC WHITEBOARDS

Price Effective - January 1, 2021



MOBILE PORCELAIN STEEL DRY ERASE

Share ideas and capture creativity with our mobile multifunctional dry erase boards. Built to last, our double-sided whiteboard writing surface is fabricated with durable porcelain and backed with steel. Resistant to scratches, dents, staining and ghosting these whiteboards can also be used as magnetic bulletin boards. The streamline frame and feet offer a sleek and contemporary appeal and nest securely for ease of storage. Available in 3 styles, our mobile porcelain steel magnetic whiteboards can be configured for any circumstance – making them perfect for capturing ideas worth sharing.

- Framework is constructed using reinforced aluminum extrusion
- All metal parts are anodized, or powder coated for an aesthetic and durable finish
- Eurocast feet are reinforced and have 3" locking casters
- Nesting frame design allows for easy space-saving storage
- Dry Erase writing surface made from high-quality durable cured porcelain backed with magnetic steel
- Annex board allows for customized lower core
- Made in the USA



How to build your SKU:

Step 1:
Choose your Model

3SLM

Step 2:
Choose your Width

49

Step 3:
Choose your Height

79

Step 4:
Choose your Frame Color

BK

Step 5:
Choose your Foot Option

4

Step 6:
Choose your Full Core Material (2XMG)
Upper Core Material

MWB

Step 6:
Choose your Lower Core Material (3SLG)

P105

(3SLG only)

MOBILE GLASS BOARDS

Model	Width	Height	Frame Color	Foot Options	Upper / Full Core Materials	Lower Core Materials (3SLG only)
2XMM Charter™	37"	66"	AA Satin Aluminum	4 4 Wheel	MWB Magnetic Porcelain Steel	FRO Frosted Acrylic
3MMM Frontage™	49"	76"	BK Black*	F Freestanding	Double sided writing surface	A1_ Colored Frosted Acrylic
3SLM Annex™	61"					F1_ Fabric 100 Series
2SLM Veranda™						F2_ Fabric 200 Series
						P1_ EchoScape™ 3/8" (9mm)
						L1_ Laminates & Wood Grains 100 Series

*Black frame not available on Frontage model

CHARTER™ MAGNETIC WHITEBOARD

CHARTER™
(Model 2XMM)
Full Panel Dual-Sided
Dry Erase



MWB **FOOT OPTIONS**

Width	Height	Weight (lbs)	Magnetic Whiteboard	4 Wheel or Freestanding
37"	66"	58	\$1,545	+\$250
37"	76"	67	\$1,600	+\$250
49"	76"	85	\$1,680	+\$250

Accessories Available for Frontage Model (Sold Separately) **SKU** **Price**

Flip Chart Clip Set
 (quantity 2)



FCC \$30

NOTE:
 All pricing in USD

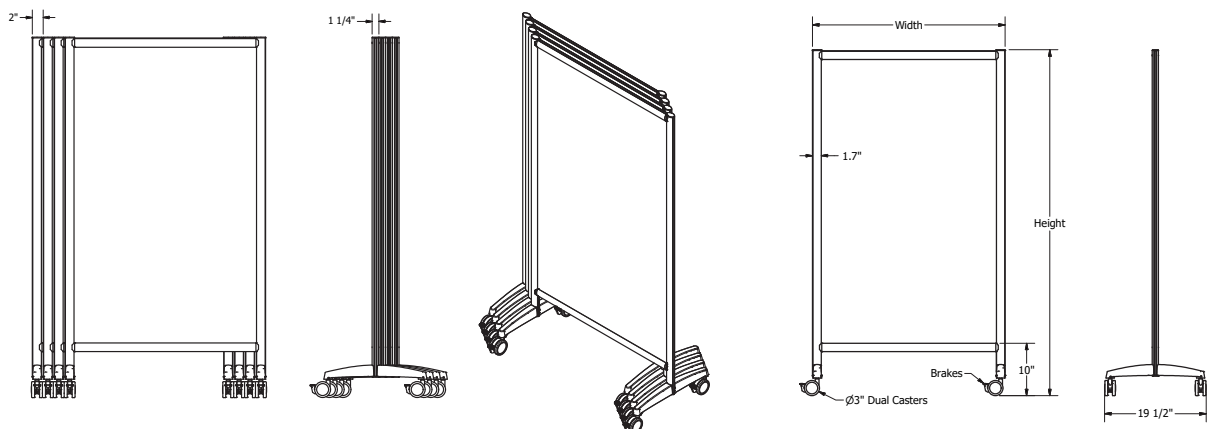

FRONTAGE™ MAGNETIC WHITEBOARD

FRONTAGE™
(Model 3MMM)
Dual-Sided Dry Erase
Whiteboard and
Magnetic Slotted Lower
Accessory Panel



MWB **FOOT OPTIONS**

Width	Height	Weight (lbs)	Magnetic Whiteboard	4 Wheel or Freestanding
37"	66"	54	\$1,345	+\$250
37"	76"	63	\$1,395	+\$250
49"	76"	80	\$1,710	+\$250

Accessories Available for Frontage Model (Sold Separately) SKU Price

Flip Chart Clip Set
 (quantity 2)



FCC

\$30

Marker Tray - Frontage Series



M-WBTR

\$65

Pencil Cup - Frontage Series



M-PTH

\$42

NOTE:

All pricing in USD

Uses M-Series Accessories

Accessories hook into slot openings on lower panel

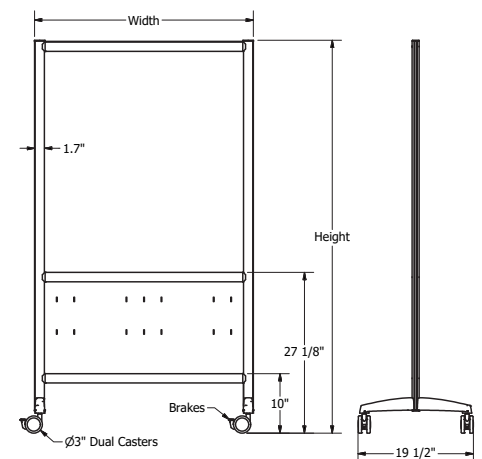

ANNEX™ MAGNETIC WHITEBOARD

ANNEX™
(Model 3SLM)
Dual-Sided Dry Erase
Whiteboard and
Lower Customized Panel with
Slatwall Accessory Rail



UPPER CORE - MAGNETIC WHITEBOARD

LOWER CORES







Width	Height	Weight (lbs)	UPPER CORE - MAGNETIC WHITEBOARD						FOOT OPTIONS
			FRO	A1_	F1_	F2_	P1_	L1_	
			Frosted Acrylic	Colored Frosted Acrylic	Fabric 100 Series	Fabric 200 Series	EchoScape™ 3/8" (9mm)	Laminate 100 Series	4 Wheel or Freestanding
37"	66"	52	\$1,290	\$1,355	\$1,305	\$1,335	\$1,240	\$1,355	+\$250
37"	76"	61	\$1,345	\$1,410	\$1,360	\$1,390	\$1,295	\$1,410	+\$250
49"	76"	77	\$1,630	\$1,700	\$1,650	\$1,690	\$1,565	\$1,710	+\$250
61"	76"	93	\$2,105	\$2,250	\$2,100	\$2,150	\$2,025	\$2,175	+\$250

NOTE:

All pricing in USD

Uses Slatwall Accessories

ANNEX™ MAGNETIC WHITEBOARDS (CONTINUED)

Accessories Available for Annex Model (Sold Separately)	SKU	Price
 <p>Flip Chart Clip Set (quantity 2)</p>	FCC	\$30
 <p>Marker Tray - Rail Series</p>	S-WBTR	\$65
 <p>Letter Tray - Rail Series</p>	S-LTT	\$50
 <p>Legal Tray - Rail Series</p>	S-LGT	\$55
 <p>Accessory Tray - Rail Series</p>	S-AT	\$40
 <p>Pen Cup - Rail Series</p>	S-PC	\$25

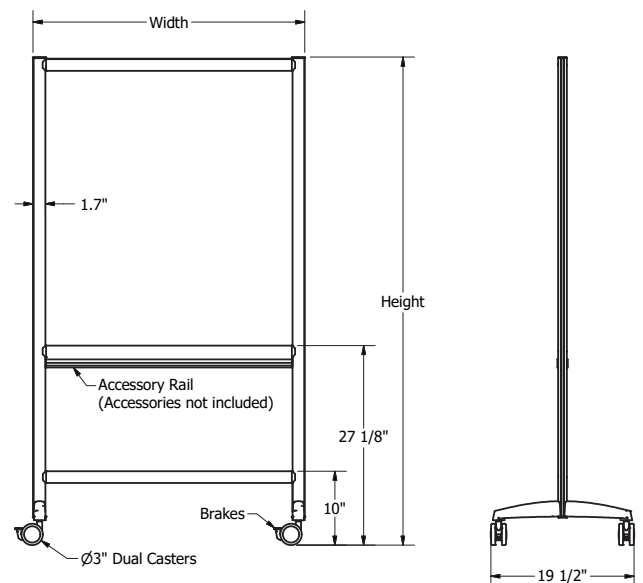

VERANDA™ MAGNETIC WHITEBOARD



VERANDA™
(Model 2SLM)
Dual-Sided Dry Erase
Whiteboard with Easel
Accessory Rail

Width	Height	Weight (lbs)	MWB	FOOT OPTIONS
			Magnetic Whiteboard	4 Wheel or Freestanding
37"	66"	50	\$1,180	+\$250
37"	76"	59	\$1,280	+\$250
49"	76"	75	\$1,545	+\$250
61"	76"	91	\$1,970	+\$250

Accessories Available for Veranda Model (Sold Separately)	SKU	Price
---	-----	-------

Flip Chart Clip Set
 (quantity 2)



FCC \$30

Marker Tray - Rail Series



S-WBTR \$65

Letter Tray - Rail Series



S-LTT \$50

Legal Tray - Rail Series



S-LGT \$55

Accessry Tray - Rail Series



S-AT \$40

Pen Cup - Rail Series



S-PC \$25

NOTE:

All pricing in USD

Uses Slatwall Accessories

Available in Magnetic Porcelain Whiteboard core only

Top of built-in slatwall accessory center rail is 37" from floor

CORE MATERIAL OPTIONS

FABRIC SERIES 100 (F1_)

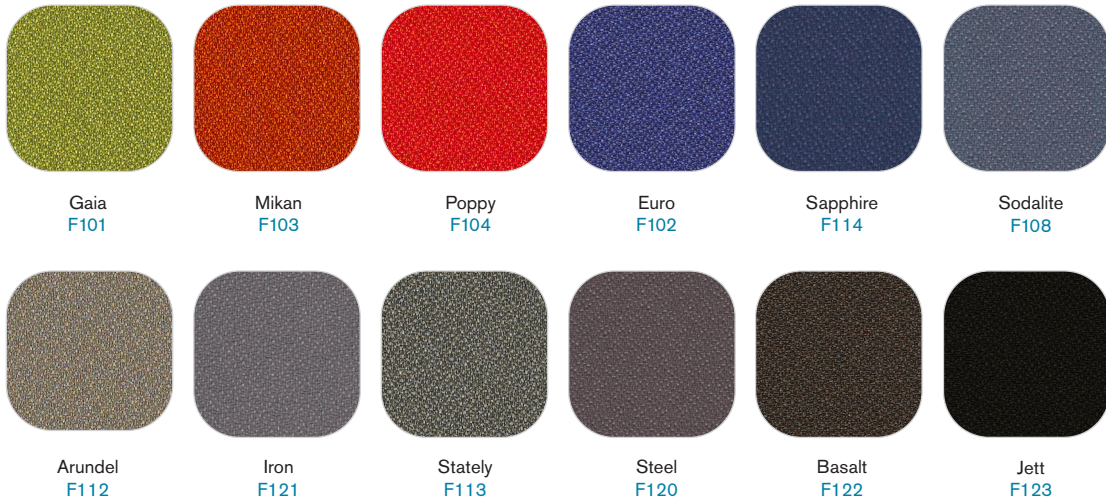

FABRIC SERIES 200 (F2_)

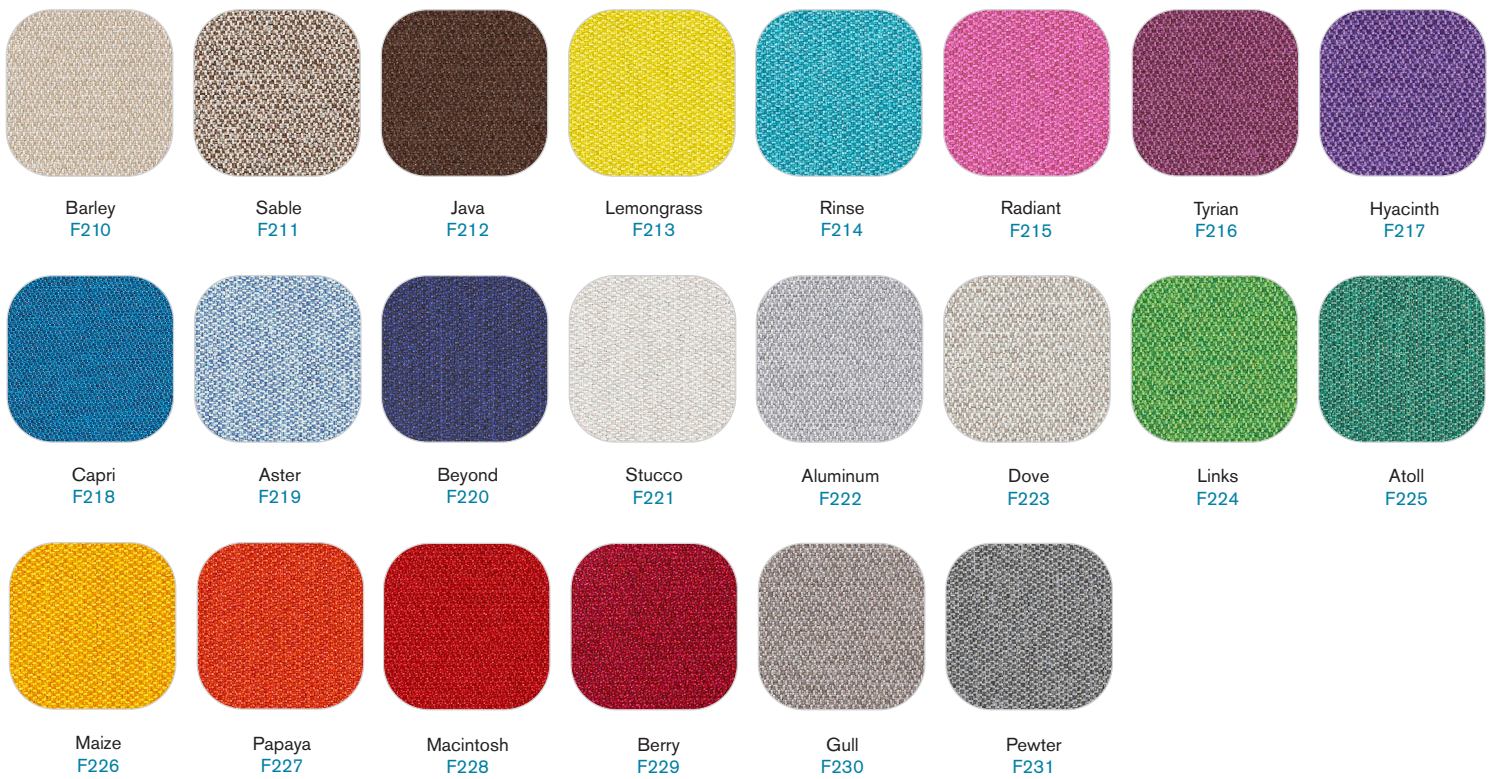

FRAME COLOR

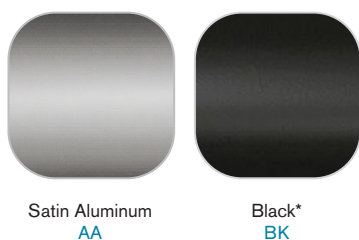

*Black frame not available on Frontage model

COLORED FROSTED ACRYLICS (A1_)

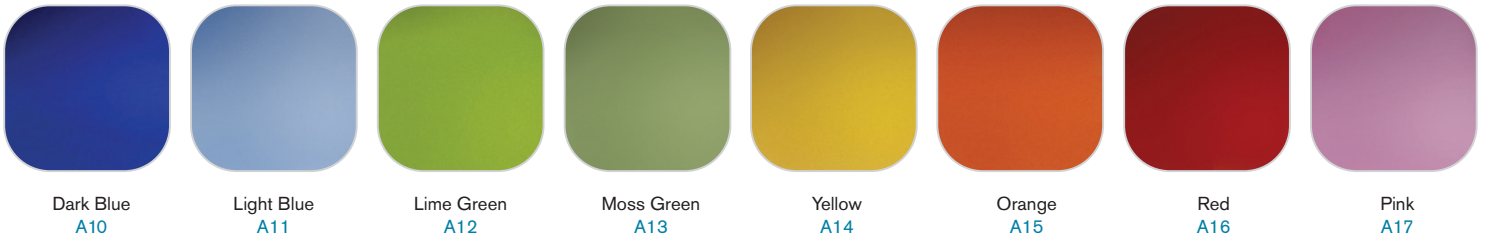

ECHOSCAPE™ 3/8" (9MM) (P1_)



LAMINATES AND WOODGRAINS SERIES 100 (L1_)

