

MAGNETIC WHITEBOARDS

Price Effective - January 1, 2022

CHARTER™



ANNEX™



MOBILE PORCELAIN STEEL DRY ERASE

Share ideas and capture creativity with our mobile multifunctional dry erase boards. Built to last, our double-sided whiteboard writing surface is fabricated with durable porcelain and backed with steel. Resistant to scratches, dents, staining and ghosting these whiteboards can also be used as magnetic bulletin boards. The streamline frame and feet offer a sleek and contemporary appeal and nest securely for ease of storage. Available in 2 styles, our mobile porcelain steel magnetic whiteboards can be configured for any circumstance – making them perfect for capturing ideas worth sharing.

- Framework is constructed using reinforced aluminum extrusion
- All metal parts are anodized, or powder coated for an aesthetic and durable finish
- Eurocast feet are reinforced and have 3" locking casters
- Nesting frame design allows for easy space-saving storage
- Dry Erase writing surface made from high-quality durable cured porcelain backed with magnetic steel
- Annex board allows for customized lower core
- Made in the USA

How to build your SKU:

Step 1:
Choose your Model

3SLM

Step 2:
Choose your Width

49

Step 2:
Choose your Height

79

Step 3:
Choose your Frame Color

BK

Step 4:
Choose your Foot Option

4E

Step 5:
Choose your Dry Erase Material

MWB

Step 6:
Choose your Lower Core Material (Annex - 3SL only)

P105

(Annex - 3SL only)

MAGNETIC WHITEBOARDS

| Model | Width | Height | Frame Color | Foot Options | Upper / Full Core Materials | Lower Core Materials (3SLM only) |
|---------------|-------|--------|-------------------|-----------------|------------------------------|--|
| 2XMM Charter™ | 37" | 66" | AA Satin Aluminum | 4E 4 Wheel | MWB Magnetic Porcelain Steel | FRO Frosted Acrylic |
| 3SLM Annex™ | 49" | 76" | BK Black | FE Freestanding | Double-Sided Writing Surface | A1_ Colored Frosted Acrylic |
| | 61" | 62" | | | | F1_ Fabric 100 Series |
| | | 72" | | | | F2_ Fabric 200 Series |
| | | | | | | P1_ EchoScape™ 3/8" (9mm) |
| | | | | | | L1_ Laminates & Wood Grains 100 Series |

MAGNETIC WHITEBOARDS - CHARTER™

CHARTER™
(Model 2XMM)
Full Panel Dual-Sided
Dry Erase



| Width | Height | Weight (lbs) | MWB | FOOT OPTIONS |
|-------|--------|--------------|---------------------|-------------------------|
| | | | Magnetic Whiteboard | 4 Wheel or Freestanding |
| 37" | 66" | 58 | \$1,600 | +\$270 |
| 37" | 76" | 67 | \$1,660 | +\$270 |
| 49" | 76" | 85 | \$1,745 | +\$270 |

| Accessories Available for Frontage Model (Sold Separately) | SKU | Price |
|--|-----|-------|
|--|-----|-------|

Flip Chart Clip Set
 (quantity 2)



FCC \$30

NOTE:
 All pricing in USD

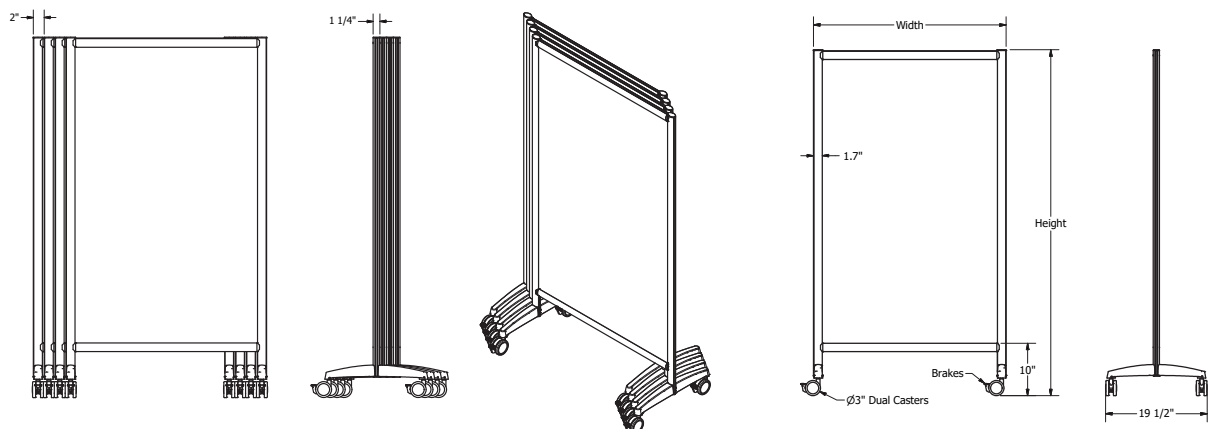

MAGNETIC WHITEBOARDS - ANNEX™

ANNEX™
(Model 3SLM)
Dual-Sided Dry Erase
Whiteboard and
Lower Customized Panel with
Slatwall Accessory Rail



| | | | UPPER CORE - MAGNETIC WHITEBOARD | | | | | | |
|-------|--------|--------------|----------------------------------|-------------------------|-------------------|-------------------|-----------------------|---------------------|-------------------------|
| | | | LOWER CORES | | | | | | |
| | | | FRO | A1_ | F1_ | F2_ | P1_ | L1_ | FOOT OPTIONS |
| Width | Height | Weight (lbs) | Frosted Acrylic | Colored Frosted Acrylic | Fabric 100 Series | Fabric 200 Series | EchoScape™ 3/8" (9mm) | Laminate 100 Series | 4 Wheel or Freestanding |
| 37" | 66" | 52 | \$1,340 | \$1,405 | \$1,365 | \$1,395 | \$1,295 | \$1,415 | +\$270 |
| 37" | 76" | 61 | \$1,400 | \$1,465 | \$1,425 | \$1,455 | \$1,355 | \$1,475 | +\$270 |
| 49" | 76" | 77 | \$1,695 | \$1,765 | \$1,725 | \$1,765 | \$1,635 | \$1,790 | +\$270 |
| 61" | 76" | 93 | \$2,185 | \$2,330 | \$2,190 | \$2,245 | \$2,115 | \$2,270 | +\$270 |

NOTE:
 All pricing in USD
 Uses Slatwall Accessories

MAGNETIC WHITEBOARDS - ANNEX™

| Accessories Available for Annex Model (Sold Separately) | SKU | Price |
|---|--------|-------|
|  <p>Flip Chart Clip Set (quantity 2)</p> | FCC | \$30 |
|  <p>Marker Tray - Rail Series</p> | S-WBTR | \$70 |
|  <p>Pen Cup - Rail Series</p> | S-PC | \$30 |

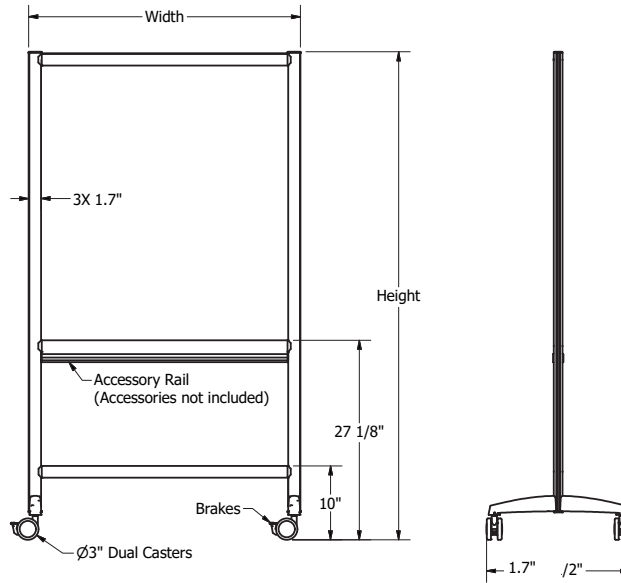

MATERIAL OPTIONS

ECHOSCAPE™ 3/8" (9MM)



Snow
P114



Oat
P116



Cocoa
P121



Sunflower
P111



Tangerine
P109



Ruby
P108



Aqua
P115



Pear
P103



Moss
P120



Spruce
P123



Sky
P117



Denim
P118



Cobalt
P102



Midnight
P119



Iced Grey
P106



Ash
P100



Slate
P105



Charcoal
P101



Jet
P122

FABRICS 100 SERIES

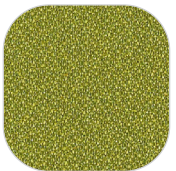

Gaia
F101

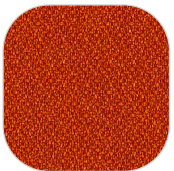

Mikan
F103

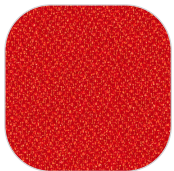

Poppy
F104

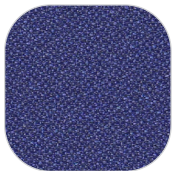

Euro
F102



Sapphire
F114

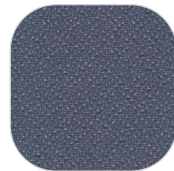

Sodalite
F108

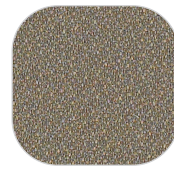

Arundel
F112

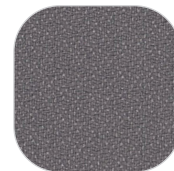

Iron
F121



Stately
F113



Steel
F120



Basalt
F122



Jet
F123

FABRICS 200 SERIES



Barley
F210



Sable
F211



Java
F212

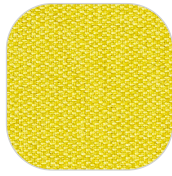

Lemongrass
F213

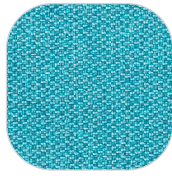

Rinse
F214

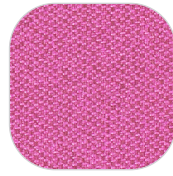

Radiant
F215

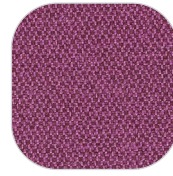

Tyrian
F216

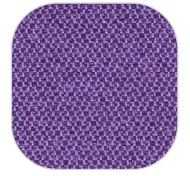

Hyacinth
F217

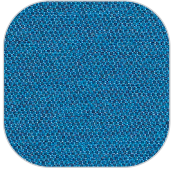

Capri
F218

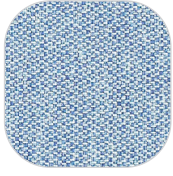

Aster
F219

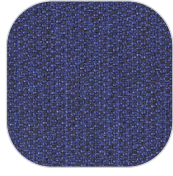

Beyond
F220



Stucco
F221



Aluminum
F222



Dove
F223

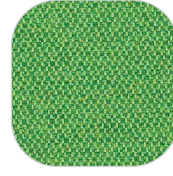

Links
F224

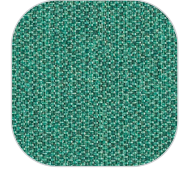

Atoll
F225

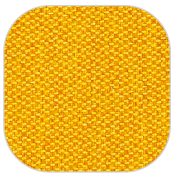

Maize
F226

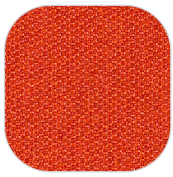

Papaya
F227

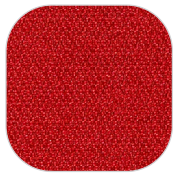

Macintosh
F228



Berry
F229



Gull
F230

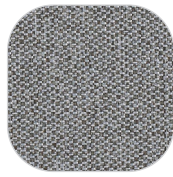

Pewter
F231

FROSTED ACRYLICS



Frosted Acrylic
FRO



Dark Blue
A10



Light Blue
A11



Lime Green
A12



Moss Green
A13



Yellow
A14



Orange
A15



Red
A16



Pink
A17

LAMINATES



Phantom Ecu
L100



Soft Gold Mesh
L101



Fusion Maple
L120



New Age Oak
L102



Huntington Maple
L118



Windswept Bronze
L103



Black Walnut
L104



Cafelle
L107



Grey Elm
L121



Bleached Legno
L105



Asian Night
L119



Smokey Brown Pear
L106



Blackened Legno
L108



Brite White
L109



Folkstone
L110

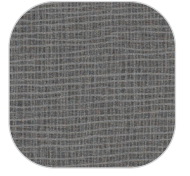

Citadel Warp
L111

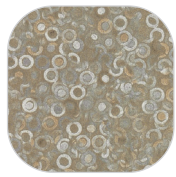

Beluga Beige
L112



White Drops
L113

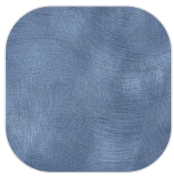

Woolamai Brush
L114



Blue Agave
L115



Hollyberry
L116



Clementine
L117



Antique Cognac Pine
L300



Recon Olive
L301



Repurposed Oak Plank
L302



Small Planked
L303



Mocha Olive
L304



Lost Pine
L305



Antique Barrel
L306



Reclaimed Oak Plank
L307

FRAMES



Satin Aluminum
AA



Black
BK