

GLASS BOARDS

FRONTAGE™

CHARTER™

ANNEX™



MOBILE GLASS DRY ERASE

Collaborate, communicate and create in style with MergeWorks mobile glass boards. Durable and built to last, our glass boards are made from high quality 1/4-inch tempered safety glass, which is 4 times stronger than regular glass. Available in clear glass and white glass, our glass boards are designed for heavy usage and never dent, stain, streak, or ghost. Glass boards are available in 3 contemporary aluminum frame designs with our reinforced Eurocast mobile feet or free-standing foot options.

- Framework is constructed using reinforced aluminum extrusions
- All metal parts are anodized, or powder coated for an aesthetic and durable finish
- Eurocast feet are reinforced and have 3" locking casters
- Nesting frame design allows for easy space-saving storage
- Glass board is available in clear and white glass
- Annex board allows for customized lower core
- Made in the USA



How to build your SKU:

Step 1:
Choose your Model

3SLG

Choose your Width

42

Step 2:

Choose your Height

66

Step 3:
Choose your Frame Color

AA

Step 4:
Choose your Foot Option

4

Step 5:
Choose your Dry Erase Material

GC

Step 6:
Choose your Lower Core Material (Annex - 3SLG only)

A11

(Annex - 3SLG only)

MOBILE GLASS BOARDS

Model	Width	Height	Frame Color	Foot Options	Dry Erase Materials	Lower Core Materials (Annex - 3SLG only)
2XMG Charter™	37"	66"	AA Satin Aluminum	4 4 Wheel	GC Clear Glass	FRO Frosted Acrylic
3MMG Frontage™	42"	76"	20 Pewter	F Freestanding	GW White Glass	A1_ Colored Frosted Acrylic
3SLG Annex™	49"		BK Black*			F1_ Fabric 100 Series
						F2_ Fabric 200 Series
						P1_ EchoScape™ 3/8" (9mm)
						L1_ Laminates & Wood Grains 100 Series

*Black frame not available on Frontage model

CHARTER™ MOBILE GLASS BOARD

CHARTER™
(Model 2XMG)
Full Panel Dual-Sided
Dry Erase Glass



Width	Height	Weight (lbs)	GC	GW	FOOT OPTIONS
			Clear Glass	White Glass	4 Wheel or Freestanding
37"	66"	59	\$820	\$1,525	+\$250
37"	76"	68	\$915	\$1,745	+\$250
42"	76"	76	\$985	\$1,905	+\$250

Accessories Available for Charter Model (Sold Separately)	SKU	Price
---	-----	-------

Flip Chart Clip Set (quantity 2)	FCC	\$30
----------------------------------	-----	------



Universal Hinge Kit Mobile Office Partitions (quantity 3)	HGEUM	\$60
---	-------	------



NOTE:
 All pricing in USD

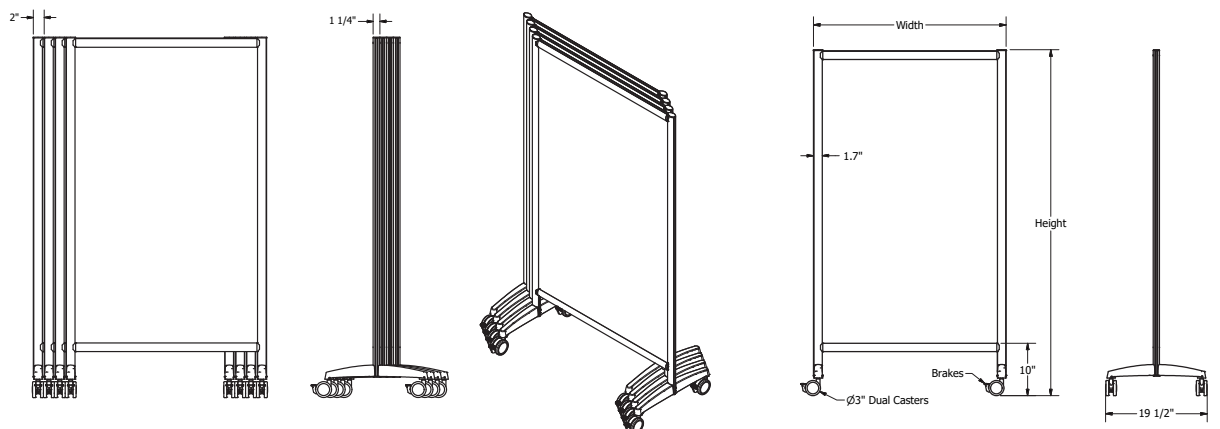





FRONTAGE™ MOBILE GLASS BOARD

FRONTAGE™
(Model 3MMG)
Dual-Sided Glass and
Magnetic Slotted Lower
Accessory Panel



Width	Height	Weight (lbs)	GC	GW	FOOT OPTIONS
			Clear Glass	White Glass	4 Wheel or Freestanding
37"	66"	54	\$960	\$1,440	+\$250
37"	76"	63	\$1,060	\$1,665	+\$250
49"	76"	81	\$1,330	\$2,135	+\$250

Accessories Available for Frontage Model (Sold Separately)	SKU	Price
--	-----	-------

Flip Chart Clip Set (quantity 2)		FCC	\$30
Universal Hinge Kit Mobile Office Partitions (quantity 3)		HGEUM	\$60
Marker Tray - M-Series		M-WBTR	\$65
Pencil Cup - M-Series		M-PTH	\$42
Letter Tray - M-Series		M-LTH	\$48

NOTE:
 All pricing in USD
 Uses M-Series Accessories
 Accessories hook into slot openings on lower panel

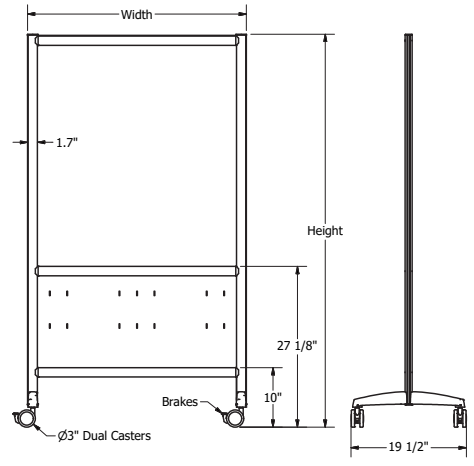

ANNEX™ MOBILE GLASS BOARD

ANNEX™
(Model 3SLG)
Dual-Sided Glass and
Lower Customized Panel with
Slatwall Accessory Rail



			UPPER CORE - CLEAR GLASS						
			LOWER CORES						
			FRO	A1_	F1_	F2_	P1_	L1_	FOOT OPTIONS
Width	Height	Weight (lbs)	Frosted Acrylic	Colored Frosted Acrylic	Fabric 100 Series	Fabric 200 Series	EchoScape™ 3/8" (9mm)	Laminate 100 Series	4 Wheel or Freestanding
37"	66"	48	\$945	\$1,010	\$955	\$980	\$890	\$1,005	+\$250
37"	76"	57	\$1,045	\$1,110	\$1,055	\$1,080	\$990	\$1,105	+\$250
49"	76"	72	\$1,250	\$1,315	\$1,265	\$1,295	\$1,180	\$1,320	+\$250

			UPPER CORE - WHITE GLASS						
			LOWER CORES						
			FRO	A1_	F1_	F2_	P1_	L1_	FOOT OPTIONS
Width	Height	Weight (lbs)	Frosted Acrylic	Colored Frosted Acrylic	Fabric 100 Series	Fabric 200 Series	EchoScape™ 3/8" (9mm)	Laminate 100 Series	4 Wheel or Freestanding
37"	66"	48	\$1,425	\$1,490	\$1,435	\$1,460	\$1,370	\$1,485	+\$250
37"	76"	57	\$1,650	\$1,715	\$1,660	\$1,685	\$1,595	\$1,710	+\$250
49"	76"	72	\$2,055	\$2,120	\$2,070	\$2,100	\$1,985	\$2,125	+\$250

NOTE:
 All pricing in USD
 Uses Slatwall Accessories

ANNEX™ GLASS BOARDS (CONTINUED)

Accessories Available for Annex Model (Sold Separately)	SKU	Price
Flip Chart Clip Set (quantity 2)	FCC	\$30
Universal Hinge Kit Mobile Office Partitions (quantity 3)	HGEUM	\$60
Marker Tray - S-Series	S-WBTR	\$65
Letter Tray - S-Series	S-LTT	\$50
Legal Tray - S-Series	S-LGT	\$55
Accessory Tray - S-Series	S-AT	\$40
Pen Cup - S-Series	S-PC	\$25

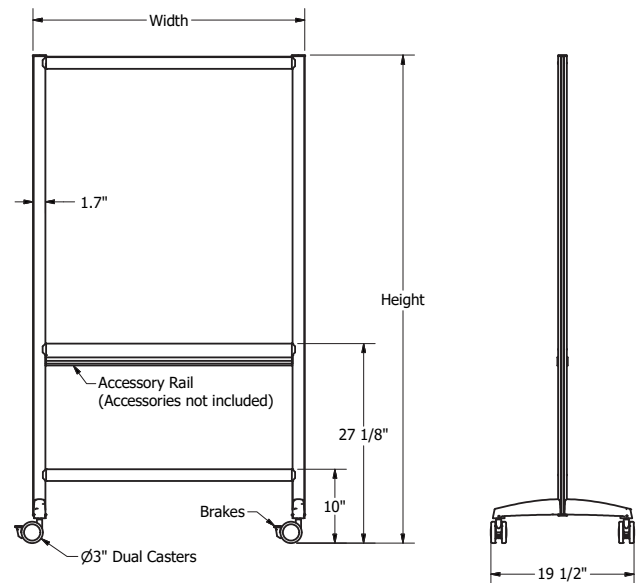

CORE MATERIAL OPTIONS

FABRIC SERIES 100 (F1_)

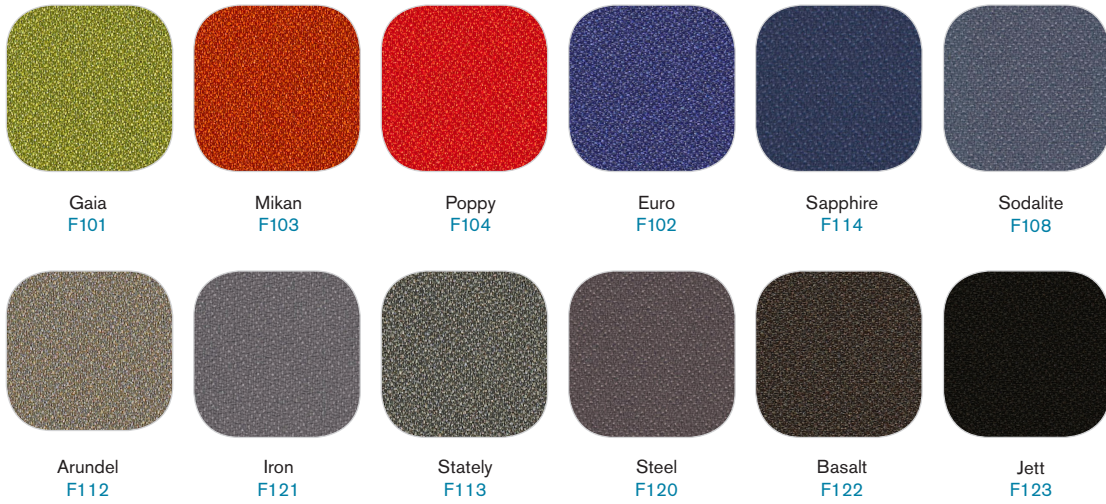

FABRIC SERIES 200 (F2_)

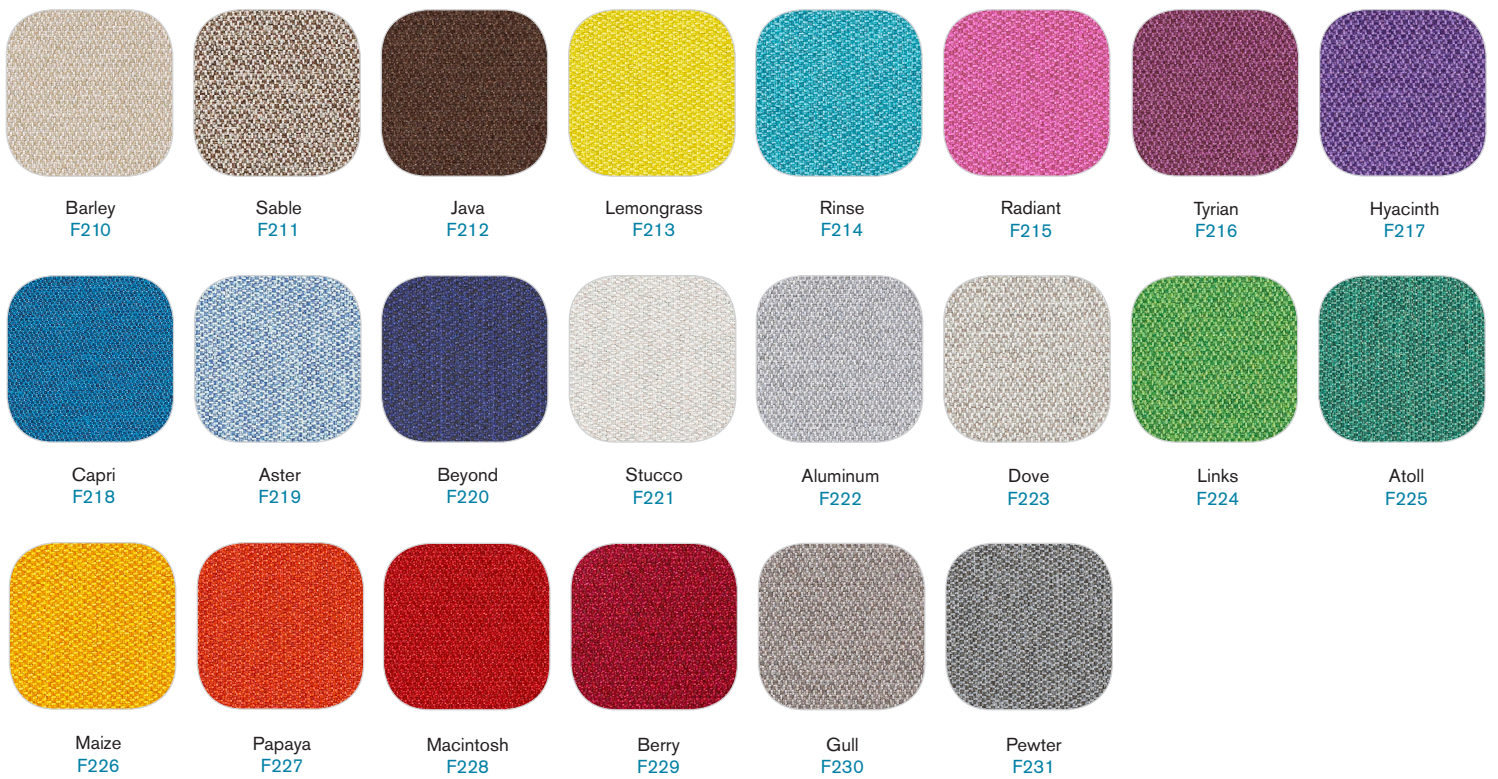

FRAME COLOR

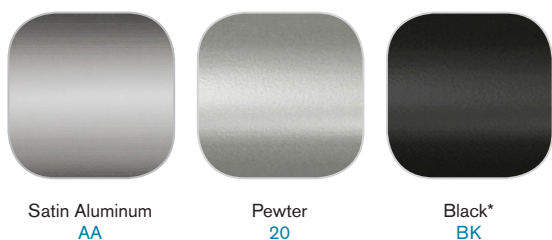

*Black frame not available on Frontage model

COLORED FROSTED ACRYLICS (A1_)

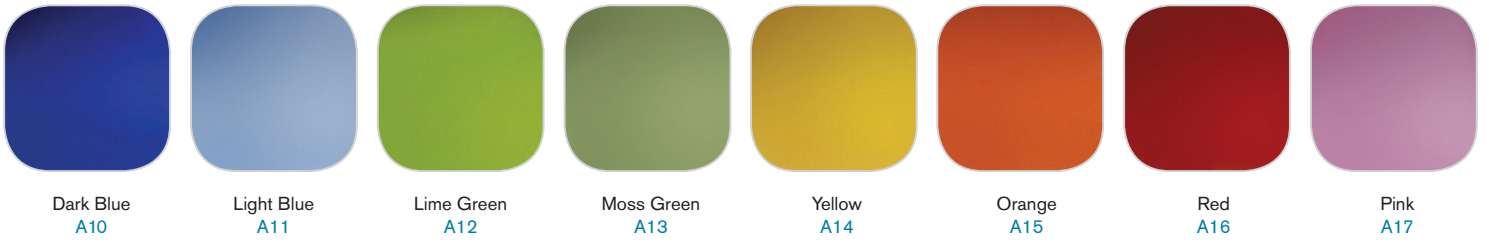

ECHOSCAPE™ 3/8" (9MM) (P1_)



LAMINATES AND WOODGRAINS SERIES 100 (L1_)

