

TRUBRITE™ WHITEBOARDS

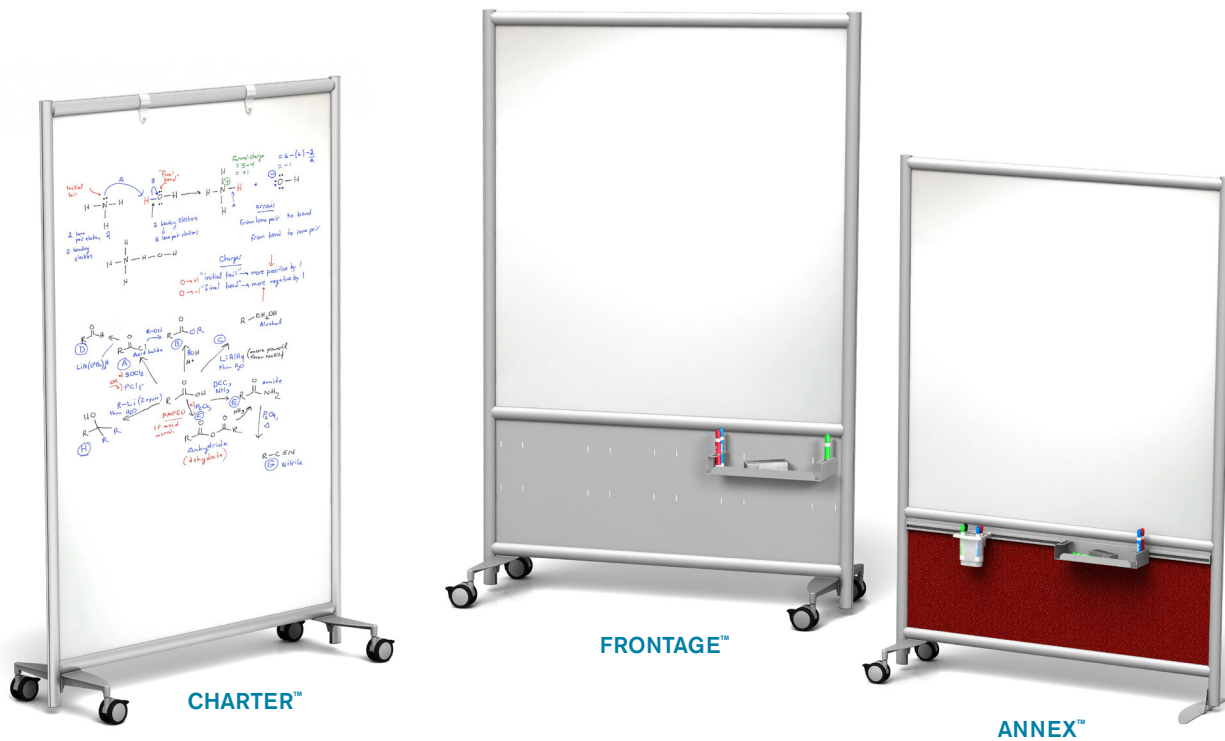

MOBILE DRY ERASE WHITEBOARD

Engineered to be lightweight, durable and mobile, our TruBrite™ whiteboards are designed and built to share ideas. Our high-quality TruBrite™ dry-erase writing surface is non-ghosting, easy to clean and economical. TruBrite™ whiteboards are available in 3 contemporary aluminum frame designs with mobile or free-standing foot options.

- Framework is constructed using aluminum extrusion
- All metal parts are anodized, or powder coated for an aesthetic and durable finish
- Our metal mobile feet have 3" locking casters
- Nesting frame design allows for easy space-saving storage
- TruBrite™ dry erase surface is non-ghosting and easy to clean
- Made in the USA

How to build your SKU:

Step 1: Choose your Model	Step 2: Choose your Width	Step 3: Choose your Height	Step 4: Choose your Frame Color	Step 5: Choose your Dry Erase Material	Step 6: Choose your Lower Core Material (Annex - 3SL only)
3SL	49	54	20	WB	P103
					(Annex - 3SL only)

MOBILE WHITEBOARDS

Model	Width	Height	Frame Color	Foot Options	Dry Erase Materials	Lower Core Materials (Annex - 3SL only)
2XM Charter™	30"	48"	AA Satin Aluminum	4 4 Wheel	WB TruBrite™ Whiteboard (Both Sides)	FRO Frosted Acrylic
3MM Frontage™	37"	54"	20 Pewter	F Freestanding	WBF1_ TruBrite™ (Side 1)/ Fabric 1_ (Side 2)	A1_ Colored Frosted Acrylic
3SL Annex™	42"	62"	BK Black*		WBF2_ TruBrite™ (Side 1)/ Fabric 2_ (Side 2)	WB TruBrite™ Whiteboard (Both Sides)
	49"	72"				F1_ Fabric 100 Series
	61"		*Black frame not available on Frontage model			F2_ Fabric 200 Series
	73"					WBF1_ TruBrite™ (Side 1)/ Fabric 1_ (Side 2)
						WBF2_ TruBrite™ (Side 1)/ Fabric 2_ (Side 2)
						P1_ EchoScape™ 3/8" (9mm)
						L1_ Laminates & Wood Grains 100 Series

CHARTER™ TRUBRITE™ MOBILE WHITEBOARD

Width	Height	Weight (lbs)	WB	FOOT OPTIONS
			TruBrite™ Whiteboard	4 Wheel or Freestanding
30"	48"	18	\$580	+\$180
30"	54"	20	\$610	+\$180
30"	62"	22	\$990	+\$180
30"	72"	25	\$1,040	+\$180
37"	48"	21	\$690	+\$180
37"	54"	23	\$720	+\$180
37"	62"	25	\$1,035	+\$180
37"	72"	29	\$1,080	+\$180
42"	48"	23	\$745	+\$180
42"	54"	25	\$775	+\$180
42"	62"	27	\$1,060	+\$180
42"	72"	31	\$1,105	+\$180
49"	48"	25	\$780	+\$180
49"	54"	28	\$810	+\$180
49"	62"	31	\$1,095	+\$180
49"	72"	35	\$1,145	+\$180



CHARTER™
(Model 2XM)
Full Panel Dual-Sided Dry Erase Board

Accessories Available for Charter Model (Sold Separately)	SKU	Price
---	-----	-------

Flip Chart Clip Set
(quantity 2)



FCC \$30

NOTE:

All pricing in USD

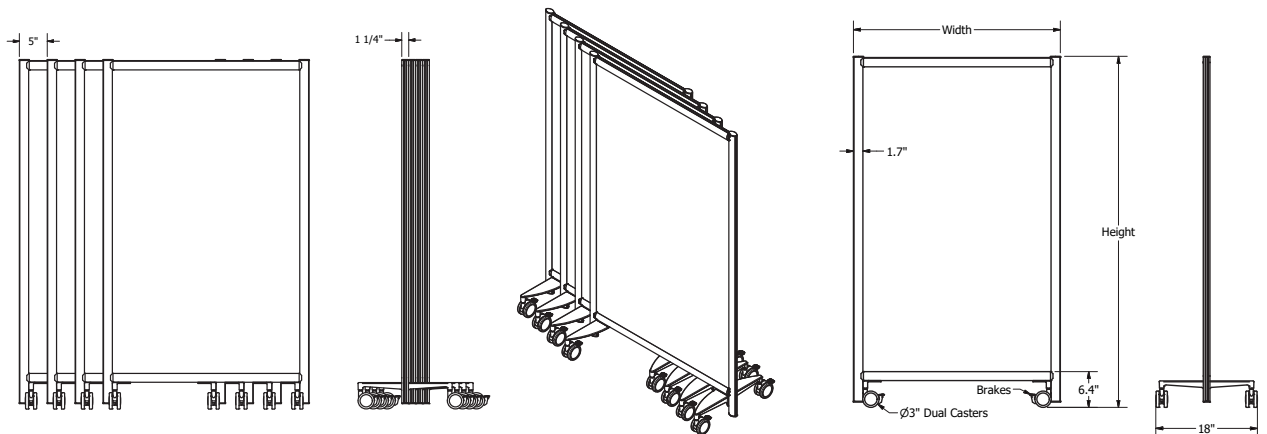

FRONTAGE™ TRUBRITE™ MOBILE WHITEBOARD

FRONTAGE™
(Model 3MM)
Dual-Sided Dry Erase
Whiteboard and
Magnetic Slotted Lower
Accessory Panel



Width	Height	Weight (lbs)	WB	WBF1__	WBF2__	FOOT OPTIONS
			TruBrite™ Whiteboard (Both Sides)	WB/Fabric 100 Series (WB Side 1/F1__ Side 2)	WB/Fabric 200 Series (WB Side 1/F2__ Side 2)	4 Wheel or Freestanding
37"	48"	26	\$795	\$830	\$850	+\$180
37"	54"	28	\$905	\$955	\$1010	+\$180
37"	62"	31	\$1,010	\$1,055	\$1,100	+\$180
37"	72"	34	\$1,065	\$1,110	\$1,155	+\$180
49"	48"	32	\$985	\$1030	\$1,060	+\$180
49"	54"	35	\$1,070	\$1,120	\$1,215	+\$180
49"	62"	38	\$1,210	\$1,260	\$1,335	+\$180
49"	72"	42	\$1,260	\$1,335	\$1,395	+\$180

Accessories Available for Frontage Model (Sold Separately)	SKU	Price
--	-----	-------

Flip Chart Clip Set (quantity 2)



FCC \$30

Marker Tray - Frontage Series



M-WBTR \$65

Pencil Cup - Frontage Series



M-PTH \$42

Letter Tray - Frontage Series



M-LTH \$48

NOTE:

All pricing in USD

Uses M-Series Accessories

Accessories hook into slot openings on lower panel

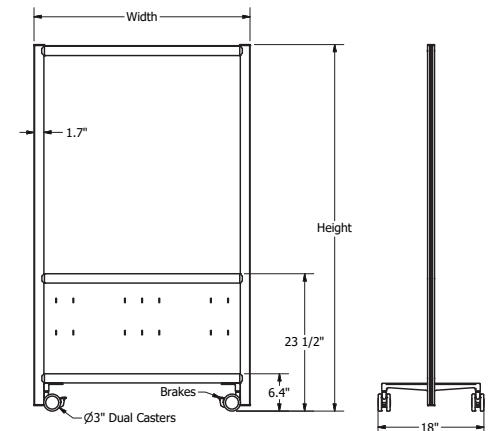

ANNEX™
(Model 3SL)
Dual-Sided Dry Erase
Whiteboard and
Lower Customized Panel with
Slatwall Accessory Rail



UPPER CORE - TRUBRITE™ (BOTH SIDES)

LOWER CORES

FOOT OPTIONS

Width	Height	Weight (lbs)	LOWER CORES									FOOT OPTIONS
			FRO	A1_	WB	F1_	F2_	WBF1_	WBF2_	P1_	L1_	
			Frosted Acrylic	Colored Frosted Acrylic	TruBrite™ Whiteboard	Fabric 100 Series	Fabric 200 Series	WB/Fabric 100 Series	WB/Fabric 200 Series	Echo-Scape™ 3/8" (9mm)	Laminate 100 Series	4 Wheel or Freestanding
37"	54"	21	\$835	\$900	\$830	\$845	\$870	\$850	\$865	\$780	\$895	+\$180
37"	62"	24	\$940	\$1,005	\$935	\$950	\$975	\$955	\$970	\$885	\$1,000	+\$180
37"	72"	27	\$985	\$1,050	\$980	\$995	\$1,020	\$1,000	\$1,015	\$930	\$1,045	+\$180
49"	54"	23	\$945	\$1,010	\$930	\$955	\$995	\$960	\$980	\$875	\$1,015	+\$180
49"	62"	26	\$1,080	\$1,145	\$1,065	\$1,090	\$1,130	\$1,095	\$1,115	\$1,010	\$1,150	+\$180
49"	72"	29	\$1,130	\$1,195	\$1,115	\$1,140	\$1,180	\$1,145	\$1,165	\$1,060	\$1,200	+\$180
61"	54"	32	\$1,410	\$1,550	\$1,425	\$1,395	\$1,440	\$1,445	\$1,470	\$1,325	\$1,470	+\$180
61"	62"	35	\$1,455	\$1,595	\$1,470	\$1,440	\$1,485	\$1,490	\$1,515	\$1,370	\$1,515	+\$180
61"	72"	40	\$1,515	\$1,655	\$1,530	\$1,500	\$1,545	\$1,550	\$1,575	\$1,430	\$1,575	+\$180
73"	54"	37	\$1,500	\$1,640	\$1,510	\$1,525	\$1,580	\$1,545	\$1,575	\$1,415	\$1,640	+\$180
73"	62"	41	\$1,550	\$1,690	\$1,560	\$1,575	\$1,630	\$1,595	\$1,625	\$1,465	\$1,690	+\$180
73"	72"	47	\$1,610	\$1,750	\$1,620	\$1,635	\$1,690	\$1,655	\$1,685	\$1,525	\$1,750	+\$180

UPPER CORE - TRUBRITE™ (SIDE 1) / FABRIC 1_ (SIDE 2)

LOWER CORES

FOOT OPTIONS

Width	Height	Weight (lbs)	LOWER CORES									FOOT OPTIONS
			FRO	A1_	WB	F1_	F2_	WBF1_	WBF2_	P1_	L1_	
			Frosted Acrylic	Colored Frosted Acrylic	TruBrite™ Whiteboard	Fabric 100 Series	Fabric 200 Series	WB/Fabric 100 Series	WB/Fabric 200 Series	Echo-Scape™ 3/8" (9mm)	Laminate 100 Series	4 Wheel or Freestanding
37"	54"	21	\$900	\$965	\$895	\$910	\$935	\$915	\$930	\$845	\$960	+\$180
37"	62"	24	\$1,005	\$1,070	\$1,000	\$1,015	\$1,040	\$1,020	\$1,035	\$950	\$1,065	+\$180
37"	72"	27	\$1,055	\$1,120	\$1,050	\$1,065	\$1,090	\$1,070	\$1,085	\$1,000	\$1,115	+\$180
49"	54"	23	\$1,015	\$1,080	\$1,000	\$1,025	\$1,065	\$1,030	\$1,050	\$945	\$1,085	+\$180
49"	62"	26	\$1,155	\$1,220	\$1,140	\$1,165	\$1,205	\$1,170	\$1,190	\$1,085	\$1,225	+\$180
49"	72"	29	\$1,230	\$1,295	\$1,215	\$1,240	\$1,280	\$1,245	\$1,265	\$1,160	\$1,300	+\$180
61"	54"	32	\$1,490	\$1,630	\$1,505	\$1,475	\$1,520	\$1,525	\$1,550	\$1,405	\$1,550	+\$180
61"	62"	35	\$1,540	\$1,680	\$1,555	\$1,525	\$1,570	\$1,575	\$1,600	\$1,455	\$1,600	+\$180
61"	72"	40	\$1,605	\$1,745	\$1,620	\$1,590	\$1,635	\$1,640	\$1,665	\$1,520	\$1,665	+\$180
73"	54"	37	\$1,610	\$1,750	\$1,620	\$1,635	\$1,690	\$1,655	\$1,685	\$1,525	\$1,750	+\$180
73"	62"	41	\$1,665	\$1,805	\$1,675	\$1,690	\$1,745	\$1,710	\$1,740	\$1,580	\$1,805	+\$180
73"	72"	47	\$1,735	\$1,875	\$1,745	\$1,760	\$1,815	\$1,780	\$1,810	\$1,650	\$1,875	+\$180

ANNEX™ TRUBRITE™ MOBILE WHITEBOARD (CONTINUED)

			UPPER CORE - TRUBRITE™ (SIDE 1) / FABRIC 2_ (SIDE 2)									
			LOWER CORES									FOOT OPTIONS
Width	Height	Weight (lbs)	FRO	A1_	WB	F1_	F2_	WBF1_	WBF2_	P1_	L1_	4 Wheel or Freestanding
			Frosted Acrylic	Colored Frosted Acrylic	TruBrite™ Whiteboard	Fabric 100 Series	Fabric 200 Series	WB/Fabric 100 Series	WB/Fabric 200 Series	Echo-Scape™ 3/8" (9mm)	Laminate 100 Series	
37"	54"	21	\$955	\$1020	\$950	\$965	\$990	\$970	\$985	\$900	\$1015	+\$180
37"	62"	24	\$1,050	\$1115	\$1,045	\$1,060	\$1,085	\$1,065	\$1,080	\$995	\$1,110	+\$180
37"	72"	27	\$1,100	\$1,165	\$1,095	\$1,110	\$1,135	\$1,115	\$1,130	\$1,045	\$1,160	+\$180
49"	54"	23	\$1,100	\$1,175	\$1,095	\$1,120	\$1,160	\$1,125	\$1,145	\$1040	\$1,180	+\$180
49"	62"	26	\$1,230	\$1,295	\$1,215	\$1,240	\$1,280	\$1,245	\$1,265	\$1,160	\$1,300	+\$180
49"	72"	29	\$1,290	\$1,355	\$1,275	\$1,300	\$1,340	\$1,305	\$1,325	\$1,220	\$1,360	+\$180
61"	54"	32	\$1,565	\$1,705	\$1,580	\$1,550	\$1,595	\$1,600	\$1,625	\$1,480	\$1,625	+\$180
61"	62"	35	\$1,615	\$1,755	\$1,630	\$1,600	\$1,645	\$1,650	\$1,675	\$1,530	\$1,675	+\$180
61"	72"	40	\$1,680	\$1,820	\$1,695	\$1,665	\$1,710	\$1,715	\$1,740	\$1,595	\$1,740	+\$180
73"	54"	37	\$1,700	\$1,840	\$1,710	\$1,725	\$1,780	\$1,745	\$1,775	\$1,615	\$1,840	+\$180
73"	62"	41	\$1,755	\$1,895	\$1,765	\$1,780	\$1,835	\$1,800	\$1,830	\$1,670	\$1,895	+\$180
73"	72"	47	\$1,825	\$1,965	\$1,835	\$1,850	\$1,905	\$1,870	\$1,900	\$1,740	\$1,965	+\$180

Accessories Available for Annex Model (Sold Separately)

	SKU	Price
Flip Chart Clip Set (quantity 2)	FCC	\$30
Marker Tray- Rail Series	S-WBTR	\$65
Letter Tray - Rail Series	S-LTT	\$50
Legal Tray - Rail Series	S-LGT	\$55
Accessory Tray - Rail Series	S-AT	\$40
Accessory Tray - Rail Series	S-AT	\$40



NOTE:

All pricing in USD

Uses Slatwall Accessories

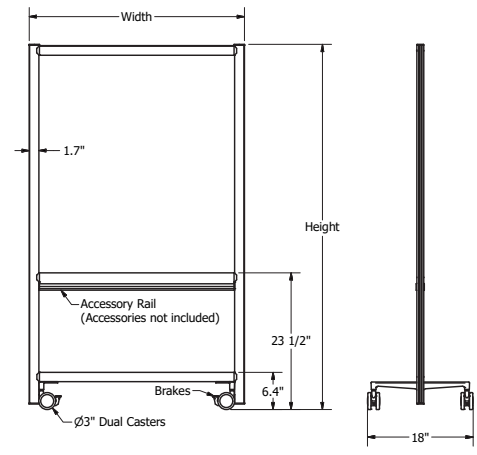

CORE MATERIAL OPTIONS

FABRIC SERIES 100 (F1_)

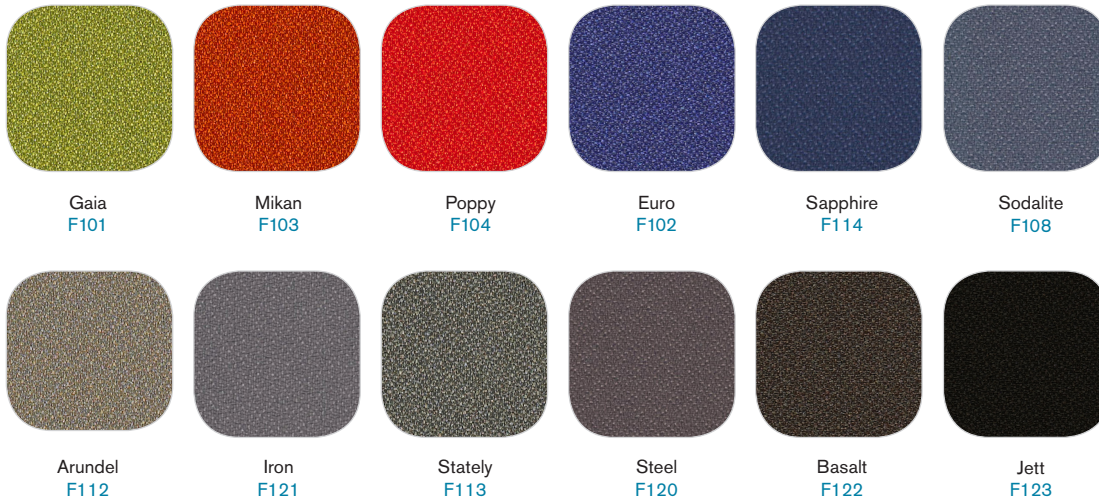

FABRIC SERIES 200 (F2_)

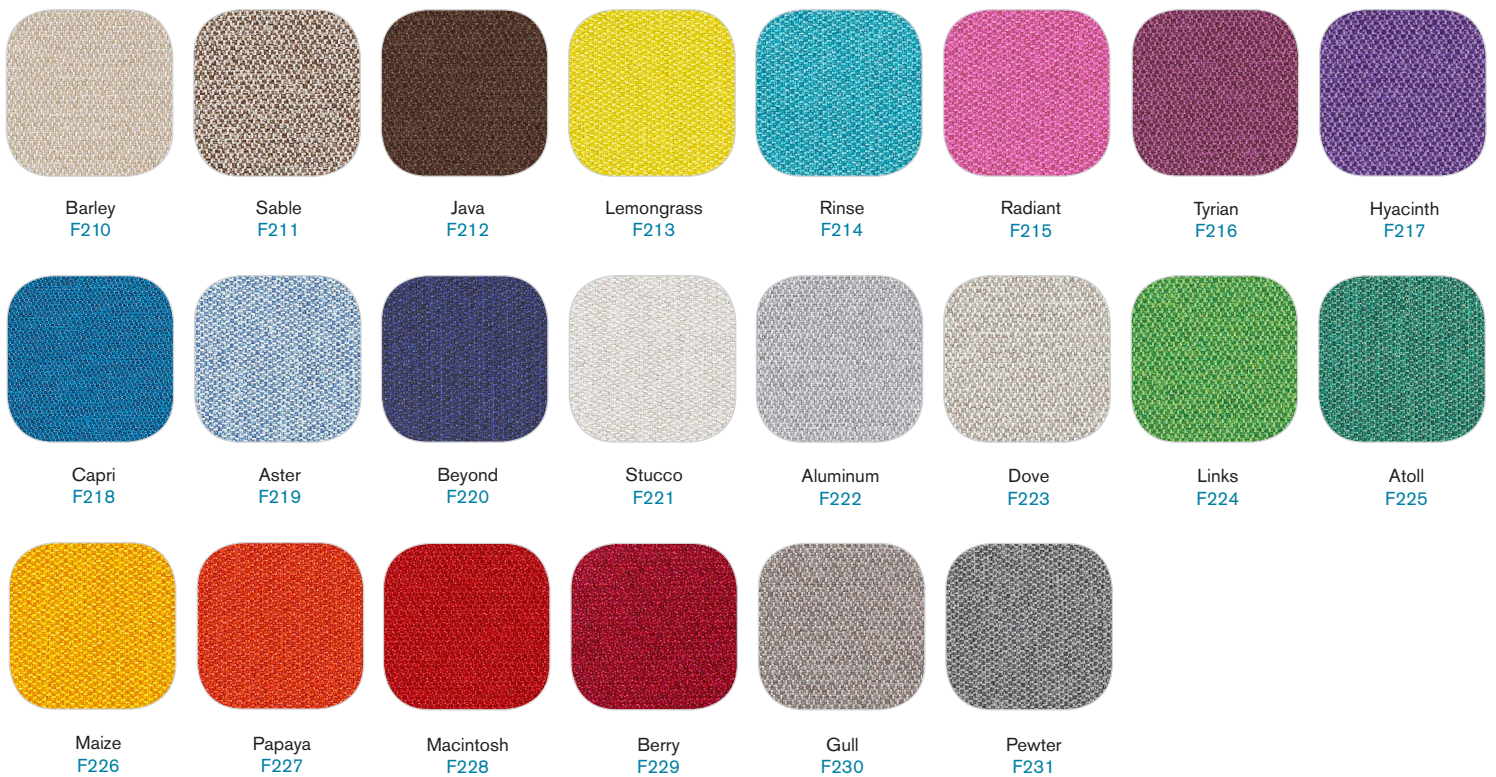

FRAME COLOR

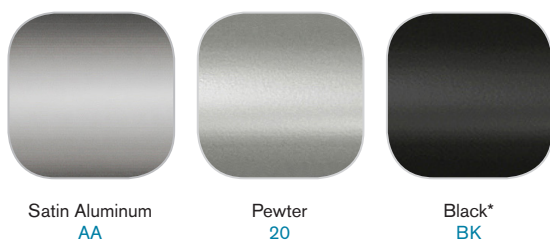

*Black frame not available on Frontage model

COLORED FROSTED ACRYLICS (A1_)

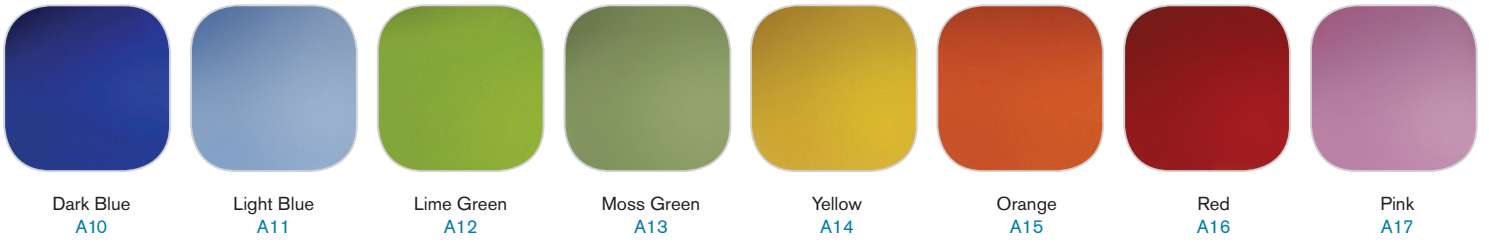

ECHOSCAPE™ 3/8" (9MM) (P1_)



LAMINATES AND WOODGRAINS SERIES 100 (L1_)

